

Contribution from the Department of Chemistry, McGill University, 801 Sherbrooke Street West, Montreal, Quebec, Canada H3A 2K6, and University of Witwatersrand, Johannesburg 2001, Republic of South Africa

Electronic Spectra of Isocyanide Derivatives of Decacarbonyldirhenium(0), $\text{Re}_2(\text{CO})_{10-n}(\text{CNR})_n$ (R = Alkyl, Aryl; $n = 1-4$)

Pierre D. Harvey,^{1a} Ian S. Butler,^{*1b} Marie de C. Barreto,^{1b} Neil J. Coville,^{1c} and Gillian W. Harris^{1c}

Received October 24, 1986

The UV-visible spectra of cyclohexane and 2-methyltetrahydrofuran (2MeTHF) solutions of isocyanide derivatives of decacarbonyldirhenium(0), $\text{Re}_2(\text{CO})_{10-n}(\text{CNR})_n$ ($n = 1-4$; R = Me, *t*-Bu, benzyl, xylenyl), have been recorded at room temperature and 77 K. There is a regular shift of the electronic absorption bands toward the red region with increasing values of n , in accord with the better σ -donor and poorer π -acceptor capacities of the CNR ligands compared to those of CO. In the case of the alkyl isocyanide derivatives, the position of the $d\sigma^* \leftarrow d\sigma$ band is the same for a given value of n and is unaffected by changes in the steric bulk of R. For the xylenyl complexes, the $d\sigma^* \leftarrow d\sigma$ band has been assigned from the low-temperature spectra. The red-shifts of the $d\sigma^* \leftarrow d\sigma$ bands of the aryl isocyanide complexes are larger than those observed in the alkyl isocyanide complexes, suggesting that aryl isocyanide ligands cause a significant inductive electron-withdrawing effect. The new intense bands in the blue region (240-300 nm) are due to metal-to-ligand charge transfer (MLCT). Attempts have been made to correlate the UV-visible results with Raman, NMR, and crystallographic data already in the literature.

Introduction

Carbonyl group substitution in metal carbonyl complexes can be effected both photochemically and thermally. In the case of the group 7² metal decacarbonyl complexes, $\text{M}_2(\text{CO})_{10}$ (M = Mn, Re), the axial CO groups are generally replaced preferentially to the equatorial ones under both photochemical³⁻⁷ and thermal conditions.⁷⁻¹⁷ Steric hindrance is believed to play a major role in this selectivity. However, exceptions to this behavior have been observed for $\text{Mn}_2(\text{CO})_{10}$ with ligands such as pyridine, cyanide, isocyanides,^{4,18} and PMe_2Ph .⁷ These experimental observations are in good agreement with the relative weakness of M-C equatorial bonds on the basis of X-ray diffraction evidence for the parent molecules and several isocyanide derivatives.¹⁹⁻²⁴ In

an earlier vibrational study, we found that there was a dependence of the totally symmetric equatorial $\nu(\text{CO})$ and $\nu(\text{Re-C})$ modes on the number of isocyanide ligands (n) in the $\text{Re}_2(\text{CO})_{10-n}(\text{CNR})_n$ complexes.²⁵ An increase in the electronic density at the metal atoms is believed to be the cause of these variations. The positions of $\nu(\text{M-M})$ modes in metal cluster complexes have sometimes provided useful information on M-M force constants and distances.²⁶ However, in our micro-Raman investigation,²⁵ the 120-cm⁻¹ band for the $\text{Re}_2(\text{CO})_{10-n}(\text{CNR})_n$ complexes, originally thought to be due to $\nu(\text{Re-Re})$, did not prove to be of any quantitative value because the degree of mixing with other low-energy vibrational modes is too great.

The electronic spectra of $\text{M}_2(\text{CO})_{10}$ (M = Mn and Re) and $\text{Co}_2(\text{CO})_8$ have been reported by several different research groups²⁷⁻³⁰ and most of the electronic bands in the 200-400-nm range have been assigned. From a recent survey of the electronic spectra of metal-metal-bonded complexes, it is clear that the $d\sigma^* \leftarrow d\sigma$ transition is usually the most intense peak in the 280-390-nm region.³¹ Moreover, theoretical calculations have shown that s-s overlap has a large influence on M-M bond properties,²⁷ and the $d\sigma^* \leftarrow d\sigma$ band position can now be predicted with reasonable accuracy.³¹ Since there is a wide variation in the σ -donor and π -acceptor properties of the CNR and CO ligands,³² the electronic density around the M-M bond can be selectively changed upon multiple substitution, causing shifting of the $d\sigma^* \leftarrow d\sigma$ transition.

The chief goal of the present paper was to see whether UV-visible spectroscopy might prove useful in establishing the relative Re-Re bond strengths in $\text{Re}_2(\text{CO})_{10-n}(\text{CNR})_n$ complexes, ($n = 0-4$; R = alkyl, aryl) and to see whether steric hindrance affects the position of the electronic bands, as observed in the vibrational spectra. These results will be compared with those obtained previously by other analytical techniques.

Experimental Section

$\text{Re}_2(\text{CO})_{10}$ was purchased from Strem Chemicals and was purified by

- (1) (a) New address: Arthur Amos Noyes Laboratories, California Institute of Technology, Pasadena, CA 91125. (b) McGill University. (c) University of Witwatersrand.
- (2) In this paper, the periodic group notation is in accord with recent actions by IUPAC and ACS nomenclature committees. A and B notation is eliminated because of wide confusion. Groups IA and IIA become groups 1 and 2. The d-transition elements comprise groups 3 through 12, and the p-block elements comprise groups 13 through 18. (Note that the former Roman number designation is preserved in the last digit of the new numbering: e.g., III \rightarrow 3 and 13).
- (3) Osborne, A. G.; Stiddard, M. H. B. *J. Chem. Soc.* **1964**, 634.
- (4) Ziegler, M. L.; Hass, H.; Sheline, R. K. *Chem. Ber.* **1965**, *98*, 2454.
- (5) Singleton, E.; Moelwyn-Hughes, J. T.; Garner, A. W. B. *J. Organomet. Chem.* **1978**, *21*, 449.
- (6) Nyman, F. *Chem. Ind. (London)* **1965**, 604.
- (7) Moelwyn-Hughes, J. T.; Garner, A. W. B.; Gordon, N. *J. Organomet. Chem.* **1971**, *26*, 373.
- (8) (a) Wawersik, H.; Basolo, F. *Chem. Commun.* **1966**, 366. (b) Wawersik, H.; Basolo, F. *Inorg. Chim. Acta* **1969**, *3*, 113.
- (9) Abel, E. W.; Butler, I. S. *J. Chem. Soc.* **1964**, 434.
- (10) Hieber, W.; Freyer, W. *Chem. Ber.* **1960**, *93*, 462.
- (11) Jolly, P. W.; Stone, F. G. A. *J. Chem. Soc.* **1965**, 5259.
- (12) Freni, M.; Giusto, D.; Romiti, P. *J. Nucl. Chem.* **1967**, *29*, 761.
- (13) Haines, L. I. B.; Poe, A. J. *J. Chem. Soc. A* **1969**, 2826.
- (14) Fawcett, J. P.; Poe, A. J.; Twigg, M. V. *J. Organomet. Chem.* **1973**, *61*, 315.
- (15) Lewis, J.; Manning, A. R.; Miller, J. R. *J. Chem. Soc. A* **1966**, 845.
- (16) Haas, H.; Sheline, R. K. *J. Chem. Phys.* **1967**, *47*, 2996.
- (17) Clark, R. J.; Hargaden, J. P.; Haas, H.; Sheline, R. K. *Inorg. Chem.* **1968**, *7*, 673.
- (18) Adams, R. D.; Chodosh, D. F. *J. Organomet. Chem.* **1975**, *87*, C48.
- (19) Albers, M. O.; Coville, N. J. *S. Afr. J. Chem.* **1982**, *35*, 139.
- (20) Robinson, D. J.; Harris, G. W.; Boeyens, J. C. A.; Coville, N. J. *J. Chem. Soc., Chem. Commun.* **1984**, 1307.
- (21) Albers, M. O.; Boeyens, J. C. A.; Coville, N. J.; Harris, G. W. *J. Organomet. Chem.* **1984**, *260*, 99.

- (22) Harris, G. W.; Boeyens, J. C. A.; Coville, N. J. *Organometallics* **1985**, *4*, 914.
- (23) Harris, G. W.; Coville, N. J. *Organometallics* **1985**, *4*, 908.
- (24) Churchill, M. R.; Amoh, K. N.; Wasserman, H. *J. Inorg. Chem.* **1981**, *20*, 1609.
- (25) Harvey, P. D.; Butler, I. S.; Harris, G. W.; Coville, N. J. *Inorg. Chem.* **1986**, *25*, 3608.
- (26) Adams, D. M. *Metal-Ligand and Related Vibrations*; Arnold: London, 1967.
- (27) Levenson, R. A. Ph.D. Thesis, Columbia University, New York, 1970.
- (28) Wrighton, M. S.; Bredesen, D. *J. Organomet. Chem.* **1975**, *50*, C35.
- (29) Wrighton, M. S.; Ginley, D. S. *J. Am. Chem. Soc.* **1975**, *97*, 2065.
- (30) Levenson, R. A.; Gray, H. B. *J. Am. Chem. Soc.* **1975**, *97*, 6042.
- (31) Abrahamson, H. B.; Frazier, C. C.; Ginley, D. S.; Gray, H. B.; Lillenthal, J.; Tyler, D. R.; Wrighton, M. S. *Inorg. Chem.* **1977**, *16*, 1557.
- (32) Cotton, F. A.; Wilkinson, G. *Advanced Inorganic Chemistry*, 3rd ed.; Wiley-Interscience: New York, 1972; pp 683-701.

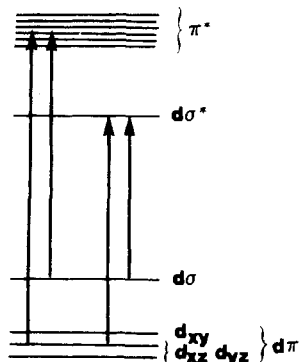

Figure 1. Partial MO diagram of $\text{Re}_2(\text{CO})_{10}$.

slow sublimation (10^{-3} Torr/ 25°C). The $\text{Re}_2(\text{CO})_{10-n}(\text{CNR})_n$ derivatives were prepared according to literature procedure.²¹⁻²³ Spectrograde cyclohexane (Anachemia Chemical Co.) was used without further purification. 2-Methyltetrahydrofuran, 2MeTHF (Aldrich Chem. Co.), was purified by refluxing over sodium/benzophenone and fractional distillation.

The UV-visible spectra were recorded on a Cary Model 17 spectrophotometer (accuracy, ± 0.4 nm; reproducibility, 0.25 nm; resolution, 0.1 nm) using 1.0-cm quartz cells. The chart scale and scan speed were 15 nm/cm and 0.5 nm/s, respectively. Samples were weighed on a Cahn RG electrobalance and placed in dry, 10-mL volumetric flasks prior to being purged with dry N_2 gas. Oxygen-free cyclohexane (obtained by purging for 1 h with N_2 gas) was then siphoned into the flask through stainless-steel needle tubing by using positive N_2 gas pressure. After complete dissolution of the complexes, the resulting solutions were quickly transferred into the UV cells for spectral analysis, again by using positive N_2 gas pressure. Each measurement was repeated two or three times using newly prepared solutions, to verify that no decomposition was occurring. The molar absorptivities at the peak maxima were reproducible to within $\pm 5\%$. A similar oxygen-free procedure was used for 77 K measurements with 2MeTHF.

Results and Discussion

The molecular structure of many of the mixed carbonyl isocyanide complexes investigated is known.¹⁹⁻²⁴ It has been shown that only the equatorial positions were substituted by isocyanide ligands, and subsequent substitutions occur on the second rhenium atom (to reduce steric hindrance) or in a cis conformation (to avoid an unfavorable trans effect). In cases where an X-ray crystal structure is lacking, vibrational spectroscopic investigations²⁵ have shown that vibrations associated with axial carbonyl groups were unaffected by substitution, while major spectral transformations occurred in the equatorial carbonyl region, further supporting the stereochemistry of substitution by isocyanide ligands observed through crystallographic investigations. The structures of all investigated complexes are known unambiguously, except for the compounds with $n = 2$ (where 1,2- and 1,1'-isomers may exist; see ref 20), and compounds where optical isomers may occur (when $n = 2$, and 3; see ref 22). Presence of such isomers is not believed to affect significantly the electronic transition energies.

1. Alkyl Isocyanide Derivatives. Detailed molecular orbital diagrams have been reported for $\text{Mn}(\text{CO})_5\text{X}$ ($\text{X} = \text{Cl}, \text{Br}, \text{I}$),^{33,34} $\text{Mn}(\text{CO})_5(\text{CN})$ and $[\text{Mn}(\text{CO})_{6-n}(\text{CNMe})_n]^+$,³⁵ and $\text{Cr}(\text{CO})_5(\text{CX})$ ($\text{X} = \text{O}, \text{S}, \text{Se}$).³⁶ In addition, the energies of the 50 molecular orbitals of $\text{Mn}_2(\text{CO})_{10}$ (D_{4d} symmetry) have been calculated by Levenson and Gray.^{27,30} Bearing in mind these earlier results and that $\text{Re}(\text{O})$ and $\text{Mn}(\text{O})$ are isoelectronic, we assumed that earlier theoretical calculations on $\text{Mn}_2(\text{CO})_{10}$ are transferrable to $\text{Re}_2(\text{CO})_{10}$ for partial spectroscopic assignment purposes.³⁷ A partial molecular orbital diagram for $\text{Re}_2(\text{CO})_{10}$ is shown in Figure 1.

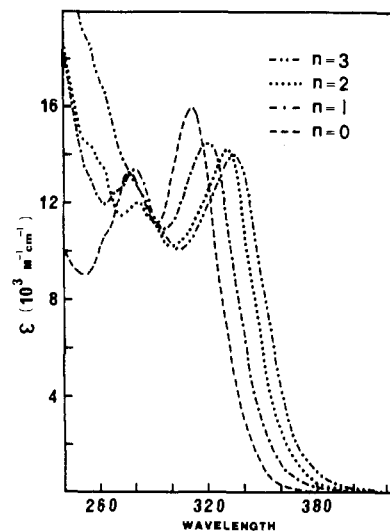

Figure 2. Room-temperature UV spectra of $\text{Re}_2(\text{CO})_{10-n}(\text{CNMe})_n$ complexes in cyclohexane solution.

Table I. Spectral Data of the $d\sigma^* \leftarrow d\sigma$ Transitions in $\text{Re}_2(\text{CO})_{10-n}(\text{CNR})_n$ ($n = 0-4$) Complexes

| | λ_{hw}^a nm | ν_{hw}^b cm^{-1} | λ_{max} nm | ν_{max} cm^{-1} | $\epsilon,^b$ M^{-1} cm^{-1} | ν_{av}^c cm^{-1} |
|---|-------------------------------|---|------------------------------|--|--|---|
| $\text{Re}_2(\text{CO})_{10}$ | 309.5 | 32 300 | 310.0 | 32 300 | 16 100 | 32 300 |
| $\text{Re}_2(\text{CO})_9(\text{CNMe})$ | 315.0 | 31 700 | 316.0 | 31 600 | 14 500 | 31 400 |
| $\text{Re}_2(\text{CO})_9(\text{CN}-t\text{-Bu})$ | 316.5 | 31 600 | 319.0 | 31 300 | 15 300 | |
| $\text{Re}_2(\text{CO})_9(\text{CNBz})$ | 316.5 | 31 600 | 319.0 | 31 300 | 15 300 | |
| $\text{Re}_2(\text{CO})_9(\text{CNXy})^d$ | 322.0 | 31 100 | 325.5 | 30 700 | 16 800 | |
| $\text{Re}_2(\text{CO})_8(\text{CNMe})_2$ | 326.0 | 30 700 | 329.0 | 30 400 | 14 100 | 30 300 |
| $\text{Re}_2(\text{CO})_8(\text{CN}-t\text{-Bu})_2$ | 326.5 | 30 600 | 331.0 | 30 200 | 14 200 | |
| $\text{Re}_2(\text{CO})_8(\text{CNBz})_2$ | 326.5 | 30 600 | 331.0 | 30 200 | 15 200 | |
| $\text{Re}_2(\text{CO})_8(\text{CNXy})_2$ | 341.0 | 29 300 | 341.5 | 29 300 | 18 800 | |
| $\text{Re}_2(\text{CO})_7(\text{CNMe})_3$ | 330.0 | 30 300 | 331.0 | 30 200 | 14 100 | 30 000 |
| $\text{Re}_2(\text{CO})_7(\text{CN}-t\text{-Bu})_3$ | 331.0 | 30 200 | 334.0 | 29 900 | 14 000 | |
| $\text{Re}_2(\text{CO})_7(\text{CNBz})_3$ | 332.0 | 30 100 | 336.0 | 29 800 | 14 800 | |
| $\text{Re}_2(\text{CO})_7(\text{CNXy})_3$ | 353.5 | 28 300 | 355.0 | 28 200 | 17 000 | |
| $\text{Re}_2(\text{CO})_6(\text{CNXy})_4$ | 390.0 | 25 600 | 392.0 | 25 500 | 15 300 | |

^a Frequency measured at half-width. ^b ± 100 $\text{M}^{-1} \text{cm}^{-1}$. ^c Average of ν_{max} values for the alkyl isocyanide derivatives. ^d Xy = xylenyl.

Figure 2 shows the electronic spectra of the $\text{Re}_2(\text{CO})_{10-n}(\text{CNMe})_n$ complexes in cyclohexane solution at room temperature. In this series, as well as for the benzyl and *tert*-butyl derivatives, there is a systematic shift of the 310-nm band of $\text{Re}_2(\text{CO})_{10}$ toward lower energy with increasing values of n , as well as a decrease in the molar absorptivity at the peak maximum. This band is also broader for all isocyanide complexes studied than that for $\text{Re}_2(\text{CO})_{10}$. Because of their shape and position (compared to those of $\text{Re}_2(\text{CO})_{10}$), these bands certainly arise from $d\sigma^* \leftarrow d\sigma$ electronic transitions. The band positions and intensities are listed in Table I. The changes in $\nu_{\text{max}}(d\sigma^* \leftarrow d\sigma)$ versus n are identical for all the alkyl isocyanide complexes. The average ν_{max} values on going from $n = 0$ to $n = 3$ are 32 300, 31 400, 30 300, and 30 000 cm^{-1} , respectively. This indicates that the electron density is progressively increasing at the metal, an effect that must reflect the stronger σ -donor and poorer π -acceptor properties of isocyanide ligands compared to those of CO. Nevertheless, the changes in electron density with increasing values of n do not seem particularly regular: $n = 0$ to $n = 1$, $\Delta = 900$ cm^{-1} ; $n = 1$ to $n = 2$, $\Delta = 1100$ cm^{-1} ; $n = 2$ to $n = 3$, $\Delta = 300$ cm^{-1} . A possible explanation of this phenomenon is that in going from zero to two CNR substituents, the metal atoms accept the excess electron density, but when $n = 3$, the metal atoms are beginning to be saturated. The high reactivity of the complexes³⁸ with $n = 4$ supports this hy-

(33) Gray, H. B.; Beach, N. A. *J. Am. Chem. Soc.* **1963**, *85*, 2922.

(34) Beach, N. A.; Gray, H. B. *J. Am. Chem. Soc.* **1968**, *90*, 5713.

(35) Saparu, A. C.; Fenske, R. F. *Inorg. Chem.* **1975**, *14*, 247.

(36) Baibich, I. M.; Butler, I. S. *Inorg. Chim. Acta.* **1985**, *89*, 73.

(37) The $d\sigma^* \leftarrow d\pi$ transition in $\text{Re}_2(\text{CO})_{10}$ is believed to be buried beneath the $d\sigma^* \leftarrow d\sigma$ band,²⁷ and two forbidden transitions are $[6e_z, d_{xz} + d_{yz}]$ and $[6e_z, d_{xz} + d_{yz}]$ to $[6b_2, 5d_{z^2}]$. The exact frequency of the $d\sigma^* \leftarrow d\pi$ transition of $\text{Mn}_2(\text{CO})_{10}$ has only been determined at low temperature (77 K).³⁰

(38) Attempts to synthesize $\text{Re}_2(\text{CO})_6(\text{CN}-t\text{-Bu})_4$ and $\text{Re}_2(\text{CO})_6(\text{CNCH}_2\text{-C}_6\text{H}_5)_4$ have failed, while $\text{Re}_2(\text{CO})_6(\text{CNMe})_4$ decomposes spontaneously in solution and under low-power laser irradiation.

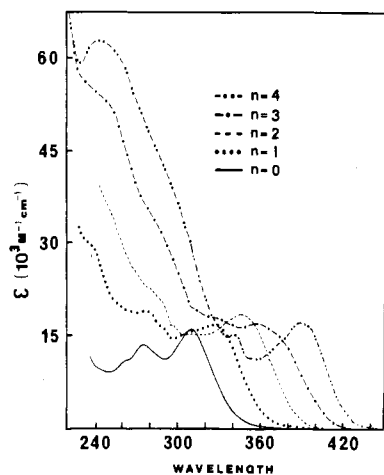

Figure 3. Room-temperature UV spectra of $\text{Re}_2(\text{CO})_{10-n}(\text{CN}(2,6\text{-Me}_2\text{C}_6\text{H}_3))_n$ ($n = 0-4$) in cyclohexane solution.

pothesis. The frequency at half-peak width for the $d\sigma^* \leftarrow d\sigma$ transition in $\text{Re}_2(\text{CO})_{10}$ is identical with ν_{max} , whereas this is not true for the isocyanide derivatives (see details in Table I). This observation is explained by the presence of unresolved electronic bands in the high-energy side of the $d\sigma^* \leftarrow d\sigma$ bands.

The $\pi^* \leftarrow d\sigma$ and $\pi^* \leftarrow d\pi$ transitions in the UV-visible spectrum of $\text{Re}_2(\text{CO})_{10}$ have been assigned previously.^{27,30} The $d\sigma^* \leftarrow d\sigma$ (main band) and $d\sigma^* \leftarrow d\pi$ (shoulder) transitions are fairly easily discerned in the UV-visible spectra of $\text{Re}_2(\text{CO})_9\text{-}(\text{CNR})$ ($R = \text{alkyl}$) in nonpolar solvents but are poorly resolved for the others. For all complexes, there is a broad intense band ($\nu_{\text{max}} = 200\text{-}230$ nm) that red-shifts with increasing extent of isocyanide substitution. This intense band is attributed to the $\pi^* \leftarrow d\pi$ transition. There are no isocyanide absorptions below 200 nm.³⁹ In a few cases, some band splittings are observed in the 240–300-nm region that are probably due to a breakdown in degeneracy of empty π^* molecular orbitals.

Howell et al.⁴⁰ have calculated the energies of the molecular orbitals for linear and bent methyl isocyanides, where there is a strong CNC angular dependence of the σ and π orbitals. These sp^2 interactions involve σ and π mixings and a large splitting and stabilization of the π_y^* and π_x^* orbitals. The crystal structures of the alkyl isocyanide complexes examined thus far and vibrational studies²⁵ indicate that the all complexed isocyanide ligands are linear, usually $176\text{-}178^\circ$,²⁰ and so it is not too surprising that the UV-visible spectra are very similar for complexes with the same value of n . Different CNC ranges have been found for $[\text{Co}_2(\text{CNMe})_{10}](\text{ClO}_4)_4$ ($170\text{-}176^\circ$),⁴¹ *trans*- $\text{Re}(\text{CNMe})_4(\text{CN})_2$ ($167^\circ \pm 5$),⁴² and $(\eta^5\text{-C}_5\text{H}_5)_2\text{Fe}_2(\text{CO})_3(\text{CNC}_6\text{H}_5)$ (131°),⁴³ and major differences are anticipated in the UV-visible spectra.

2. Xylenyl Isocyanide Derivatives. The room-temperature UV-visible spectra of the xylenyl isocyanide complexes ($n = 1-4$) in cyclohexane solutions are shown in Figure 3; there is only slight similarity with the UV-visible spectra of the alkyl isocyanide complexes. The lowest energy band of $\text{Re}_2(\text{CO})_{10}$ ($d\sigma^* \leftarrow d\sigma$) shifts and increases in intensity on going from $n = 0$ to $n = 2$, but loses intensity for $n = 3$, and is significantly broader than the $d\sigma^* \leftarrow d\sigma$ band observed for the alkyl isocyanide complexes. The low-temperature (77 K) UV-visible spectra of the xylenyl isocyanide complexes are shown in Figure 4. The lowest energy band strongly sharpens and blue-shifts slightly upon cooling, which confirms the presence of $d\sigma^* \leftarrow d\sigma$ transitions in these systems.

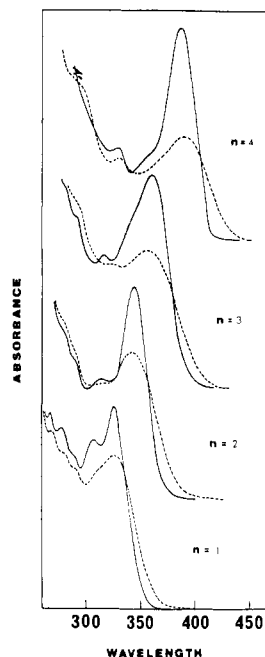

Figure 4. Comparison of the absorption spectra of $\text{Re}_2(\text{CO})_{10-n}(\text{CN}(2,6\text{-Me}_2\text{C}_6\text{H}_3))_n$ ($n = 1-4$) complexes in 2MeTHF at room temperature (---) and 77 K (—). Corrected for the base line and glass contraction.

However, the interpretation of the remainder of the electronic spectra is more complicated as several new features of strong intensity appear in the blue region upon substitution of xylenyl isocyanide ligands.

Bursten and Fenske⁴⁴ have reported MO calculations for CNC_6H_5 . It is found that the π^* molecular orbitals of the phenyl group are appreciably more stable than the CN π^* orbitals. For the xylenyl isocyanide complexes, additional benzene electronic transitions are now possible: $\pi^*(\text{Bz}) \leftarrow d\sigma$ and $\pi^*(\text{Bz}) \leftarrow d\pi$, i.e. MLCT. The linear CNR structure²⁰ favors some resonance considerations.²³ These new transitions will overlap with the other electronic bands and complicate the UV-visible spectra. The strong intensities, along with the pronounced and regular red-shift of these new features with the variation of n , strongly suggest the presence of MLCT's. In $\text{Re}_2(\text{CO})_6(\text{CN}(\text{xylenyl}))_4$, the maximum of a strong UV band appears at ~ 250 nm and possesses a molar absorptivity of $\sim 63\,000$ $\text{M}^{-1} \text{cm}^{-1}$. The MLCT transitions in $\text{Re}_2(\text{CO})_{10}$ are believed to lie above $52\,500$ cm^{-1} with a molar absorptivity greater than $100\,000$ $\text{M}^{-1} \text{cm}^{-1}$.²⁸

At 77 K, the peak maximum of the $d\sigma^* \leftarrow d\sigma$ transitions are 32 400, 30 800, 29 200, 27 900, and 25 900 cm^{-1} for $n = 0-4$, respectively. The red-shift upon multiple substitution is quasi-regular: 1600, 1600, 1300, and 2000 cm^{-1} for $n = 0 \rightarrow 1$, $1 \rightarrow 2$, $2 \rightarrow 3$, and $3 \rightarrow 4$, respectively. The average is 1600 cm^{-1} and is significantly larger than the one observed for the alkyl isocyanide complexes ($\Delta \approx 800$ cm^{-1}). This indicates that a strong inductive electron-withdrawing effect due to the xylenyl group is taking place. (Conjugation through the π -system requires proper orientation of the π^* molecular orbitals. In the solid state, the complex with $n = 2$ shows that the ring of one CNR ligand is inclined at 73.1° to the plane formed by the nearest equatorial CO groups, while the other CNR ligand is essentially coplanar. For the complex with $n = 4$, the xylenyl rings are all coplanar²⁰ (6.6 , 5.7 , 4.8 , and 2.4°)).

The $d\sigma^* \leftarrow d\pi$ band in $\text{Mn}_2(\text{CO})_{10}$ has been found to be red-shifted.^{27,30} For $\text{Re}_2(\text{CO})_{10}$, this transition lies on the high-energy side of the $d\sigma^* \leftarrow d\sigma$ band. It is particularly well resolved at low temperature (77 K). In this work, it is likely that the same situation occurs, where the newly resolved feature may be at-

(39) Ashfold, M. N. R.; Simmons, J. P. *Spectrochim. Acta, Part B* **1978** *33B*, 1263.

(40) Howell, J. A. S.; Saillard, J. Y.; LeBeuze, A.; Jaouen, G. *J. Chem. Soc., Dalton Trans.* **1982**, 2533.

(41) Cotton, F. A.; Dunne, T. G.; Wood, J. S. *Inorg. Chem.* **1964**, *3*, 1495.

(42) Hulme, R.; Powell, H. M. *J. Chem. Soc.* **1957**, 719.

(43) Joshi, K. K.; Mills, O. S.; Pauson, P. L.; Shaw, B. W.; Stubbs, W. M. *Chem. Commun.* **1965**, 181.

(44) Bursten, B. E.; Fenske, R. F. *Inorg. Chem.* **1977**, *16*, 963.

(45) Herzberg, G. *Molecular Spectra and Molecular Structure*; Van Nostrand: New York, 1950; Vol. III.

tributed to this particular transition.

3. Attempted Correlations of the UV-Visible, Raman, ^{13}C NMR, and X-ray Diffraction Data. Table I presents some spectroscopic results for free and complexed isocyanide ligands. It is known that in going from CNMe to CN-*t*-Bu, there is a decrease in *s* character of the σ -bonding orbital for the free ligand.⁴⁶ The order of ^{13}C NMR shifts observed for the terminal carbon (carbene) in the CNR ligands with changes in R is xylenyl \gg Me $>$ *t*-Bu. The decrease in $\nu(\text{CN})$ with increasing size of the R group, Me $<$ benzyl $<$ *t*-Bu and xylenyl, indicates a decrease in N-C bond strength. On the basis of ^{13}C NMR⁴⁶ and vibrational data,²⁵ the xylenyl isocyanide ligand has a large amount of sp^2 character at its terminal carbon atom. Stephany et al.⁴⁶ have suggested that bending of the CNC angle could take place due to the bulkiness of the alkyl R groups.⁴⁷ Consequently, there is a rehybridization of the N atom from sp to sp^2 , thereby explaining the decrease in $\nu(\text{CN})$. The UV-visible data given in Table I suggest that for complexed ligands, the σ -donor capacities should decrease in the order xylenyl \gg benzyl \sim *t*-Bu $>$ Me, in disagreement with the ^{13}C NMR results for the free ligands. Therefore, the σ -donor properties are modified during substitution as evidenced by the change in $\nu(\text{CN})$ between the free and complexed ligand (there is an increase in *s* character in N-C bond). When *n* is changed, $\nu(\text{CN})$ remains essentially unchanged, indicating that the CN bond distances and CNC angles remain the same from complex to complex. Since the value of $\nu(\text{CN})$ in the complexes increases as xylenyl $<$ *t*-Bu $<$ benzyl $<$ Me, it is believed that this same order represents the order of decreasing σ -capacity of the linear isocyanide ligands (in agreement with the UV-visible results). Thus, the relative σ -donor and π -acceptor properties of the complexed isocyanides estimated by electronic spectroscopy seem to correlate reasonably well with the Raman results.

The actual Re-Re distances are as follows: $\text{Re}_2(\text{CO})_{10}$, 3.041 (1) Å;²² $\text{Re}_2(\text{CO})_9(\text{CN-}t\text{-Bu})$, 3.048 (1) Å;¹⁹ $\text{Re}_2(\text{CO})_8(\text{CN-(2,6-Me}_2\text{C}_6\text{H}_3)_2)$, 3.048 (1) Å;²⁰ $\text{Re}_2(\text{CO})_7(\text{CN(CH}_2\text{C}_6\text{H}_5)_3)$, 3.049 (1) Å;²⁰ $\text{Re}_2(\text{CO})_6(\text{CN(2,6-Me}_2\text{C}_6\text{H}_3)_4)$, 3.079 (1) Å.²⁰ The weakening of the M-M bond in $\text{M}_2(\text{CO})_{10}$ and $\text{MM}'(\text{CO})_{10}$ complexes (M and M' = Mn, Tc, Re) has been discussed by Brown et al.⁴⁸ Woodruff⁴⁹ derived an empirical equation relating

the M-M force constant ($F/\text{mdyn } \text{Å}^{-1}$) and the M-M separation ($r/\text{Å}$) for the 5d element:

$$r(5d) = 2.01 + 1.31 \exp(-F/2.36) \quad (1)$$

Woodruff calculated the Re-Re separation (3.01 Å), and it appears to be 0.03 Å shorter than the one evaluated by crystallography. Using the previously published Raman data,²⁵ we obtained similar results for our complexes. The problems that are encountered here are the facts that this relationship is not accurate enough to take into account small perturbations and the M-M stretching modes are extensively mixed for these complexes.

Since we know that electronic spectroscopy looks at electronic transitions only, the problem with the vibrational spectroscopy of $\text{Re}_2(\text{CO})_{10-n}(\text{CNR})_n$ complexes seems to be resolved. Our experimental results have shown clear monotonic progressions of the $d\sigma^* \leftarrow d\sigma$ position versus *n* (see Figures 2-4). The accuracy of the experimental method is reasonable at room temperature and particularly good at 77 K. To date, no empirical relationship between the metal-metal separations and metal-to-metal electronic transitions exists. Unfortunately, it is clear that due to the lack of crystallographic data, very little can be done in this respect. Nevertheless, there is an apparent correlation between the metal-metal bond length and the $d\sigma^* \leftarrow d\sigma$ band positions for the xylenyl complexes (three data points), and a monotonic bond lengthening is expected with increase of *n*.

Acknowledgment. This research was generously supported by grants from the NSERC (Canada) and the FCAR (Quebec). P.D.H. thanks the NSERC, the FCAR, and McGill University (McConnell and Stewart Foundations) for the award of graduate fellowships.

Registry No. $\text{Re}_2(\text{CO})_{10}$, 14285-68-8; $\text{Re}_2(\text{CO})_9(\text{CNMe})$, 95672-45-0; $\text{Re}_2(\text{CO})_9(\text{CN-}t\text{-Bu})$, 95463-95-9; $\text{Re}_2(\text{CO})_9(\text{CNBz})$, 95590-07-1; $\text{Re}_2(\text{CO})_9(\text{CNXy})$, 95590-13-9; $\text{Re}_2(\text{CO})_8(\text{CNMe})_2$ (1,1'-isomer), 95590-17-3; $\text{Re}_2(\text{CO})_8(\text{CNMe})_2$ (1,2-isomer), 95590-16-2; $\text{Re}_2(\text{CO})_8(\text{CN-}t\text{-Bu})_2$ (1,1'-isomer), 95672-44-9; $\text{Re}_2(\text{CO})_8(\text{CN-}t\text{-Bu})_2$ (1,2-isomer), 95590-05-9; $\text{Re}_2(\text{CO})_8(\text{CNBz})_2$, 95590-08-2; $\text{Re}_2(\text{CO})_8(\text{CNXy})_2$, 95406-94-3; $\text{Re}_2(\text{CO})_7(\text{CNMe})_3$, 95406-95-4; $\text{Re}_2(\text{CO})_7(\text{CN-}t\text{-Bu})_3$, 95590-06-0; $\text{Re}_2(\text{CO})_7(\text{CNBz})_3$, 95590-09-3; $\text{Re}_2(\text{CO})_7(\text{CNXy})_3$, 95590-14-0; $\text{Re}_2(\text{CO})_6(\text{CNXy})_4$, 95406-96-5.

(46) Stephany, R. W.; de Bie, M. J.; Drenth. *Org. Magn. Reson.* **1974**, *6*, 45.

(47) Knol, D.; Koole, N. J.; de Bie, M. J. A. *Org. Magn. Reson.* **1976**, *8*, 213.

(48) Brown, D. A.; Chambers, W. J.; Fitzpatrick, N. J.; Rawlinson, S. N. *R. J. Chem. Soc. A* **1971**, 720.

(49) Woodruff, W., unpublished results. A brief report of Woodruff's rule for the 4d series has been published: Miskowski, V. M.; Dallinger, R. F.; Morris, D. E.; Spies, G. H.; Woodruff, W. H. *Inorg. Chem.* **1987**, *2*, 2127.

Contribution from the Chemistry Department,
University of Virginia, Charlottesville, Virginia 22901

Infrared Spectra of Hydrazine and Products of Its Reactions with HF, F₂, and O₃ in Solid Argon

Robert Lascola, Robert Withnall, and Lester Andrews*

Received August 6, 1987

Hydrazine, N₂H₄, and its reactions with HF, F₂, and O₃ have been studied in an argon matrix. Vibrational assignments have been made for hydrazine, including clarification of the ν_6 , ν_{10} , and $2\nu_7$ bands. Complexation of N₂H₄ with HF produced a strong band at 2928 cm⁻¹ ($\nu_4(\text{HF})$) and sharp bands at 940 and 922 cm⁻¹ ($\nu_1(\text{HF})$), as well as several perturbed N₂H₄ submolecule absorptions; the frequencies of these bands suggest a chelated structure similar to that for the NH₂OH-HF complex. Hydrazine and fluorine reacted during deposition to give the NH₂NHF-HF complex ($\nu_8 = 3113$ cm⁻¹, $\nu_1 = 726, 680$ cm⁻¹). Reaction of hydrazine and ozone produced hydroxyhydrazine, NH₂NHOH, and minor products during deposition; photolysis increased the yield of hydroxyhydrazine. Evidence for an intramolecular hydrogen bond was found for NH₂NHOH. This matrix study presents the first spectroscopic evidence for both NH₂NHF and NH₂NHOH.

Introduction

One of the advantages of the matrix isolation technique over other spectroscopic methods is that it can be used to study reactive molecules and intermediates that would otherwise be difficult to observe. An example of such a molecule is hydrazine, which is sufficiently reactive to have been used as a rocket fuel.¹ Past

experiments involving hydrazine in the gas phase,²⁻⁵ in a N₂ matrix,⁶ and as a salt⁷ have shown some disagreement in vibra-

(1) Schmidt, E. W. *Hydrazine and Its Derivatives*; Wiley: New York, 1984; and references therein.

(2) Giguere, P. A.; Liu, I. J. *J. Chem. Phys.* **1952**, *20*, 136.